

# Introduction to Triga Components

## Feet

Two versions - one is wide for lateral stability and the other (pictured) is low-profile.

Female connector



## Uprights

Vertical structural pieces, typically 1-4 sections, each up to 48" long.

Male connector

Threaded collar



Uprights are built by inserting the male connector into the female connector and tightening the threaded collar. Both connectors are keyed so the connection can only be made one way. This requires no tools.



Upright top-cap indicates this is the top section of an upright.

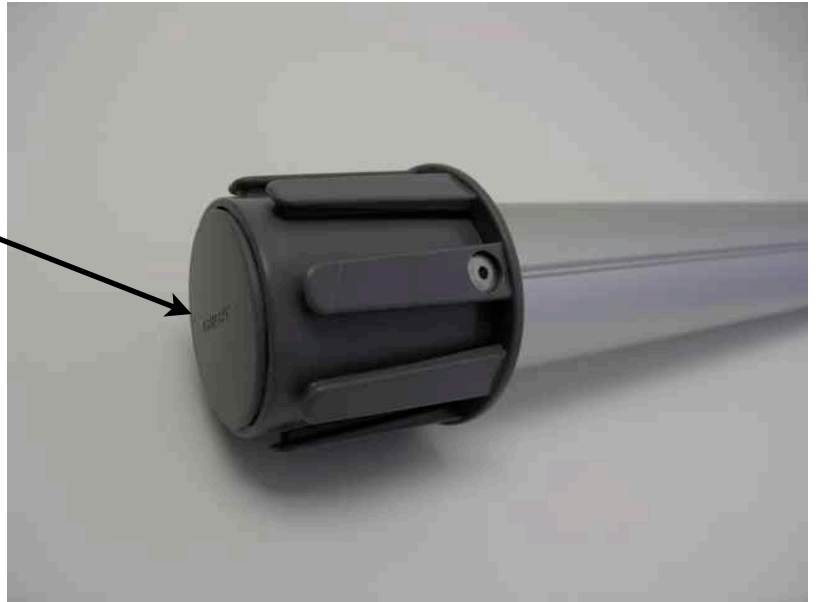

**Cross-bar**

Horizontal structural pieces, typically up to 48" long.

Graphic tensioner (closed)

Cross-link

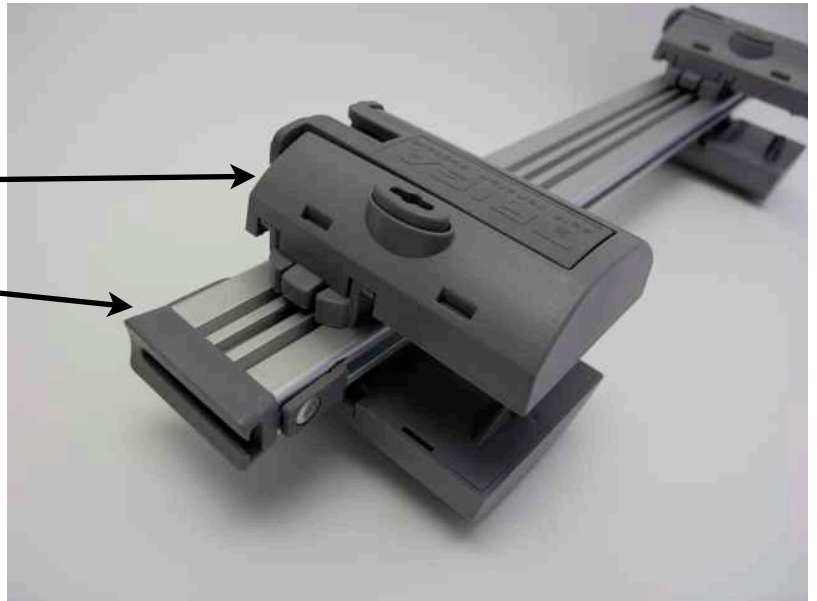

**Graphic Tensioner Activation**

This is done after the graphic is installed to pull it tight.

Open position

Activation trigger

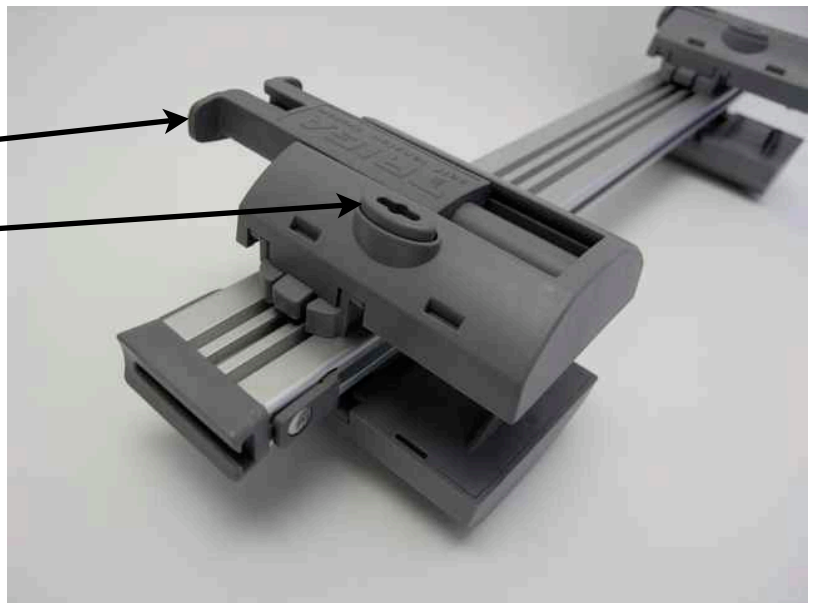

### Link-cuff

Cross-bars are “linked” to uprights by fastening a cross-link to a link-cuff. This is done without tools. Most common “links” are made in-line at 180° (to extend in a straight line) or at 90° (to create a corner).



### Multiple angles are possible



### Graphic-rail

Horizontal pieces that hold PVC strips installed in the bottom and top of graphics. Mounted into tensioners, they pull graphics tight when “Trigas” are activated.

Hinge block (insert into tensioner)

End piece

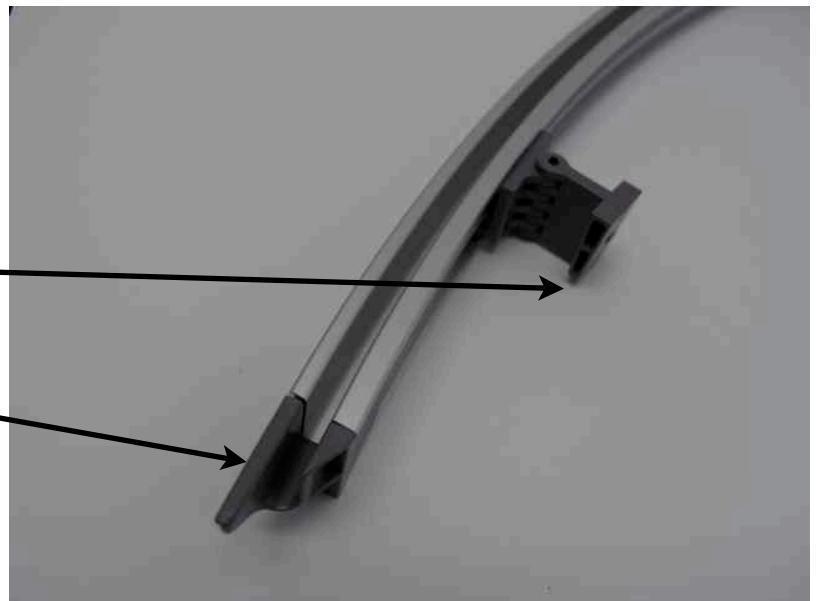

**Graphic-rail installed in tensioner**

